

Tractor-Setting Type
Deep Aerator

TDA1200

BARONESS
Maintenance Machine

Parts Catalog

2011.2~

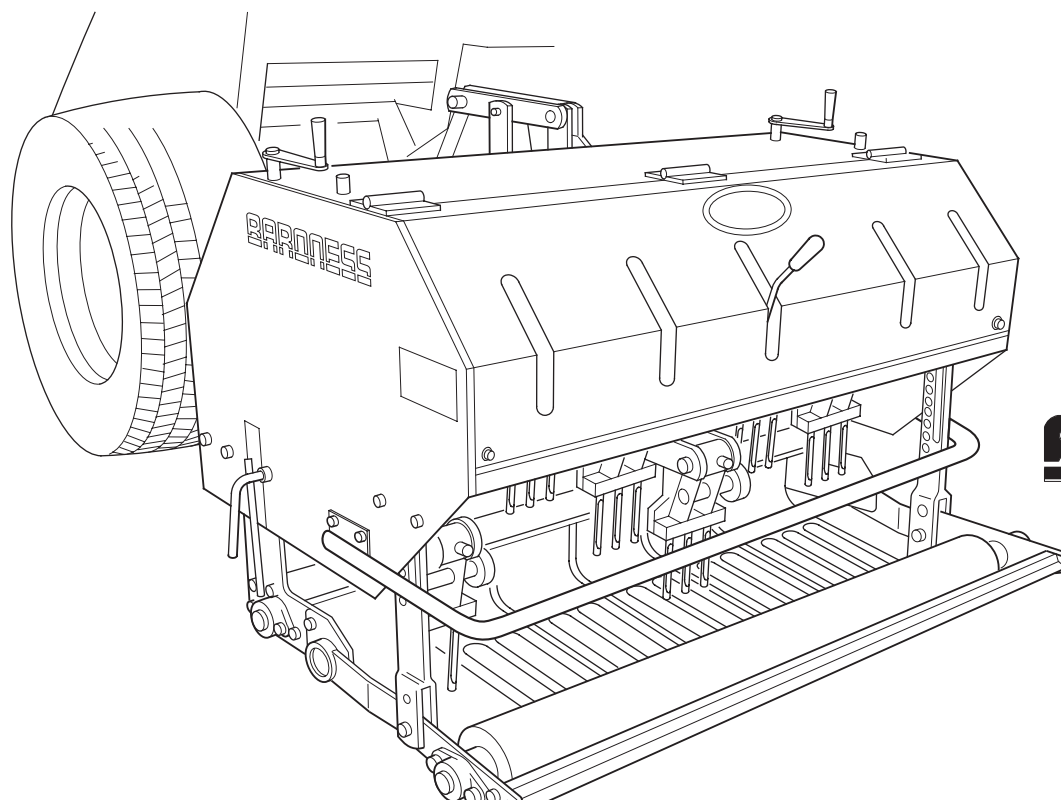

BARONESS®

BEVATTNINGSTEKNIK AB
Helsingborgsvägen 578, Varalöv
262 96 ÄNGELHOLM, SWEDEN

Telefon: +46 431 22250
Email : info@bevattningsteknik.se eller philip@bevattningsteknik.se
www.bevattningsteknik.se

CONTENTS

Parts Catalog	2
1.Frame and cover	3
2.Front/rear rollers	5
3.Gearbox	9
4.Crank	11
5.Accessories and options	15

BARONNESS

Maintenance Machine

Tractor-Setting Type Deep Aerator

TDA1200

Parts Catalog

(Inquiry about the machine)

The models may change sequentially. When making an inquiry about this machine, please advise us of the model and serial number.

The contents of this catalog are subject to change without notice.

(Placing an order for parts)

Parts are computer controlled. However, in order to prevent delivery of wrong parts, 0

please describe the catalog No., code No., and part name when placing an order.

Example	:	Catalog No.	Code No.	Part name	Qty
		1-1	K0013161201	16 heat treated bolt 120	1

1. Frame and cover

TDA1200

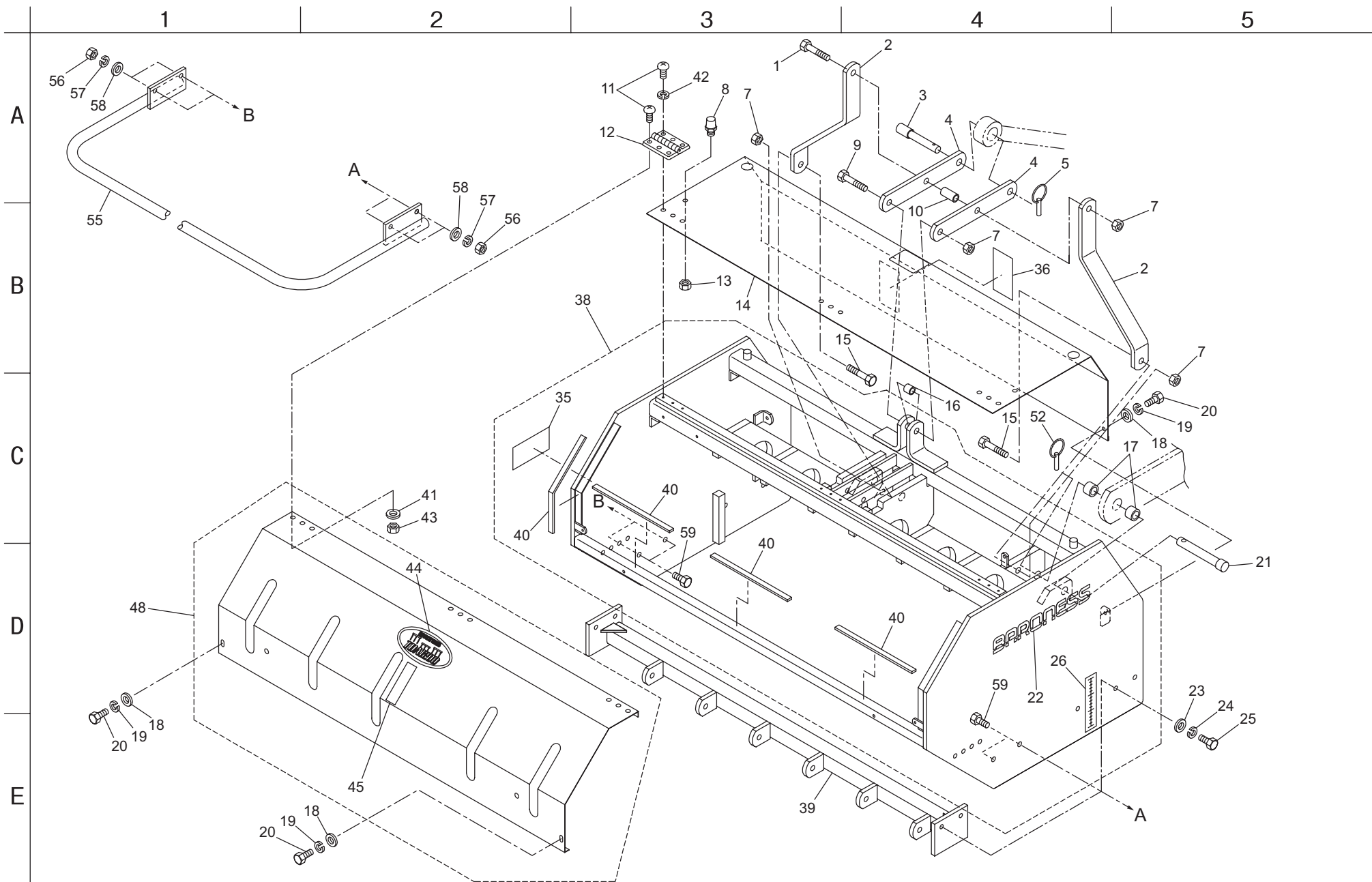

Cat No.	Code No.	Part name	Qty	Remarks
1 - 1	K0013161201	16 heat treated bolt 120	1	
1 - 2	TDA12000103ZR	Lower link coupler	2	
1 - 3	K6030191002	19 flat head pin 100	1	
1 - 4	TDA12000102ZR	Upper link coupler	2	
1 - 5	K6061060002	6 clip pin	1	
1 - 6				
1 - 7	K0144160002	16U nut	4	
1 - 8	K4049030000	Rubber stopper KI-30	2	
1 - 9	K0013160952	16 heat treated bolt 95	1	
1 - 10	K6212001822	16STKM collar 2245	1	
1 - 11	K0042050152	5+ round machine screw 15	18	
1 - 12	K4520000230	6 resin hinge with hole 100	3	
1 - 13	K0144080002	8U nut	2	
1 - 14	TDA12000113ZR	Front cover	1	
1 - 15	K0013160602	16 heat treated bolt 60	2	
1 - 16	K6212001802	16STKM collar 2220	1	
1 - 17	K6212001812	22.2STKM collar 3222.4	4	
1 - 18	K5000080002	8 washer	6	
1 - 19	K0200080002	8S washer	6	
1 - 20	K0000080152	8 bolt 15	6	
1 - 21	TDA12000116Z8	22 hardened flat head pin 145	2	
1 - 22	K4201000140	BARONESS mark 45 white	2	
1 - 23	K5000120002	12 washer	4	
1 - 24	K0200120002	12S washer	4	
1 - 25	K0010120302	12 heat treated bolt 30	4	
1 - 26	K4209001140	Scale mark 150A	2	
1 - 27				
1 - 28				
1 - 29				
1 - 30				
1 - 31				
1 - 32				
1 - 33				
1 - 34				
1 - 35	K4205001750	Handling precautions labe	1	

Cat No.	Code No.	Part name	Qty	Remarks
1 - 36	K4205001760	PTO caution level	1	
1 - 37				
1 - 38	TDA12000151Z0	Frame COMP	1	
1 - 39	TDA12000112BR	Box mounting bracket	1	
1 - 40	K4228000110	Rubber sponge 15300	5	
1 - 41	K5000050002	5 washer	9	
1 - 42	K0200050002	5S washer	9	
1 - 43	K0144050002	5U nut	9	
1 - 44	TDA12000127Z0	TDA1200 mark	1	
1 - 45	K4203001390	Crank effect speed level	1	
1 - 46				
1 - 47				
1 - 48	TDA12000150A0	Rear cover COMP	1	
1 - 49				
1 - 50				
1 - 51				
1 - 52	K6061100002	10 clip pin	2	
1 - 53				
1 - 54				
1 - 55	TDA12002101ZR	Protection pipe	1	
1 - 56	K0100100002	10 nut	4	
1 - 57	K0200100002	10 washer	4	
1 - 58	K5000100002	10S washer	4	
1 - 59	K0000100352	10 bolt 35	4	

1. Frame and cover

TDA1200

2. Front/rear roller

TDA1200

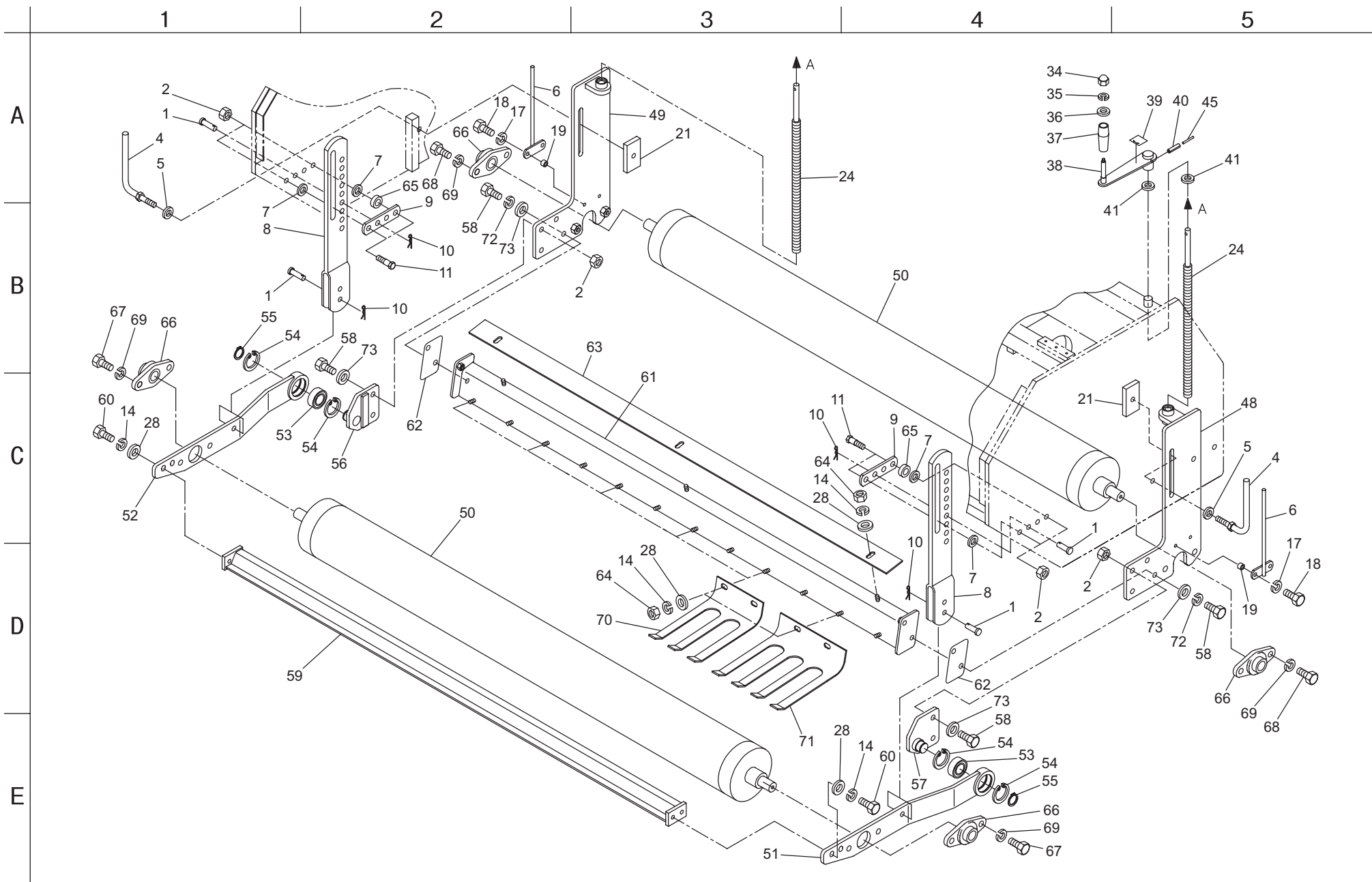

Cat No.	Code No.	Part name	Qty	Remarks
2 - 1	K6031120403	12 hardened flat head pin 40	4	
2 - 2	K0144120002	12U nut	8	
2 - 3				
2 - 4	TDA12000125A8	Roller holding fixture	2	
2 - 5	K0213120002	12 disc spring washer 1H	2	
2 - 6	TDA12000122ZD	Depth gauge	2	
2 - 7	K5012312222	2.3SPCC washer 1222	4	
2 - 8	TDA12000123ZD	Roller hanger	2	
2 - 9	TDA12000124ZD	Roller holding plate	2	
2 - 10	K0361000008	10KS snap pin	4	
2 - 11	K0071000372	Hydraulic motor bolt	4	
2 - 12				
2 - 13				
2 - 14	K0200100002	10S washer	19	
2 - 15				
2 - 16				
2 - 17	K0200080002	8S washer	4	
2 - 18	K0000080302	8 bolt 30	4	
2 - 19	K6212000982	8.5STKM collar 149.5	4	
2 - 20				
2 - 21	TDA12000115ZD	Tightening plate	2	
2 - 22				
2 - 23				
2 - 24	TDA12000106Z0	Adjusting screw	2	
2 - 25				
2 - 26				
2 - 27				
2 - 28	K5000100002	10 washer	19	
2 - 29				
2 - 30				
2 - 31				
2 - 32				
2 - 33				
2 - 34	K0100060002	6 nut	2	
2 - 35	K0200060002	6S washer	2	

Cat No.	Code No.	Part name	Qty	Remarks
2 - 36	K5000060002	6 washer	2	
2 - 37	K1301000120	25 lever grip 70	2	
2 - 38	K7100000112	Up-down handle	2	
2 - 39	K4203001060	Depth adjusting handle plate	2	
2 - 40	K0320050251	5 spring pin 25	2	
2 - 41	K5021012200	1NBS55 washer 1220	4	
2 - 42				
2 - 43				
2 - 44				
2 - 45	K0320030251	3 Spring pin 25	2	
2 - 46				
2 - 47				
2 - 48	TDA16000104ZD	Front roller bracket 8 right	1	
2 - 49	TDA16000105ZD	Front roller bracket 8 left	1	
2 - 50	TDA12000145ZD	Roller	2	
2 - 51	TDA16000141ZD	Rear roller bracket 8 right	1	
2 - 52	TDA16000140ZD	Rear roller bracket 8 left	1	
2 - 53	K0613060050	Bearing 60052RDC3	2	
2 - 54	K0402047001	Stop ring R47	4	
2 - 55	K0401025001	Stop ring S25	2	
2 - 56	TDA16000143ZD	Bracket mounting plate left	1	
2 - 57	TDA16000144ZD	Bracket mounting plate right	1	
2 - 58	K0013120402	12 heat treated bolt 40	8	
2 - 59	TDA12000142ZD	Scraper rear	1	
2 - 60	K0010100252	10 heat treated bolt 25	4	
2 - 61	TDA12000146ZD	Lawn presser mounting bracket	1	
2 - 62	TDA16000119Z2	Adjusting plate A	2	
2 - 63	TDA12000147ZD	Scraper front	1	
2 - 64	K0100100002	10 nut	15	
2 - 65	K6212002362	13.5STKM collar 2214	2	
2 - 66	K0661205000	Square flange unit UCFL205	4	
2 - 67	K0010140302	14 heat treated bolt 30	4	
2 - 68	K0013140452	14 heat treated bolt 45	4	
2 - 69	K0200140002	14S washer	8	
2 - 70	TDA12000332ZD	Lawn push plate A	5	

2. Front/rear roller

TDA1200

2. Front/rear roller

TDA1200

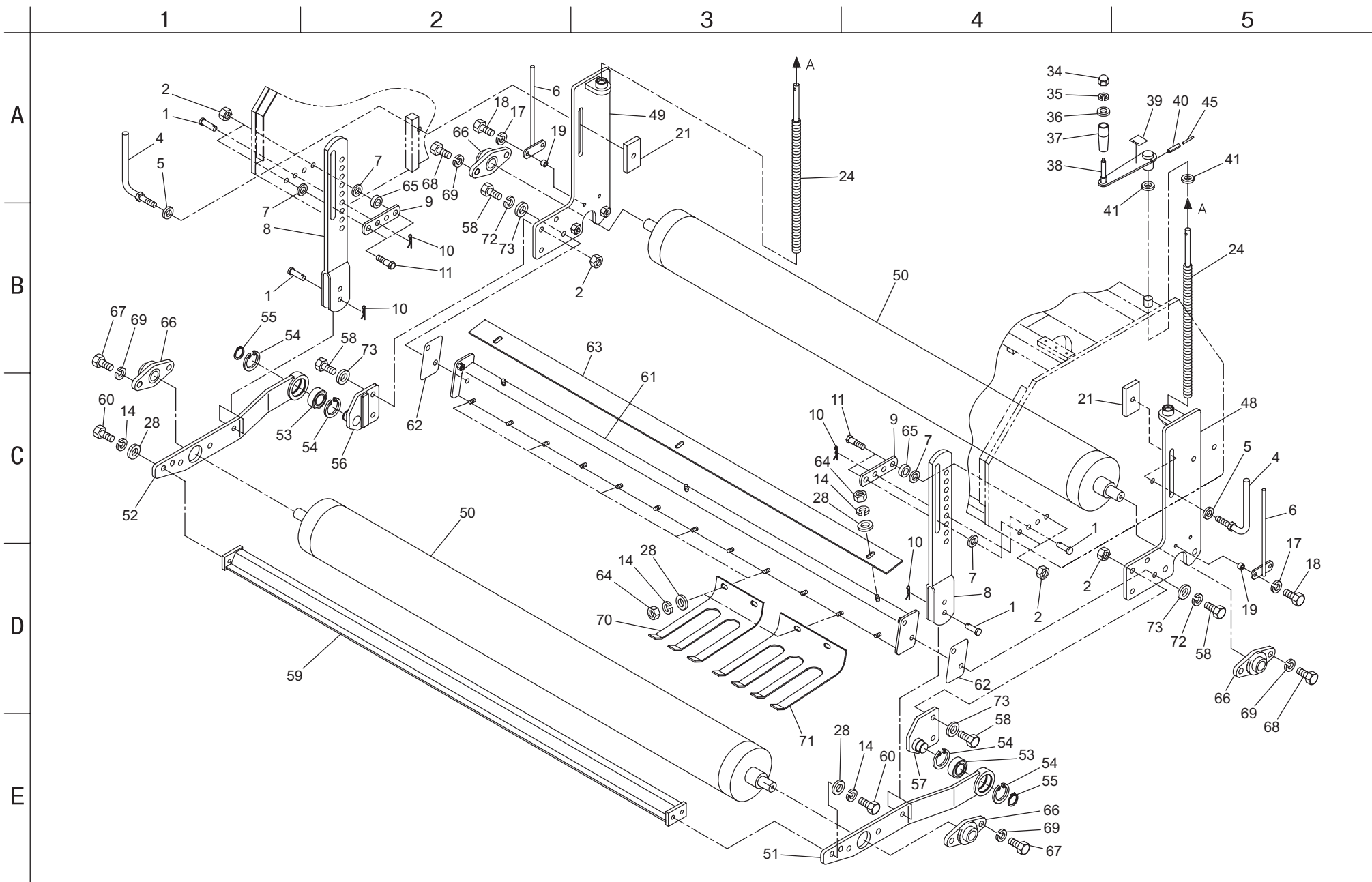

Cat No.	Code No.	Part name	Qty	Remarks
2 - 71	TDA12000333ZD	Lawn push plate B	1	
2 - 72	K0200120002	12S washer	4	
2 - 73	K5000120002	12 washer	8	

Cat No.	Code No.	Part name	Qty	Remarks

2. Front/rear roller	TDA1200
----------------------	---------

3. Gearbox

TDA1200

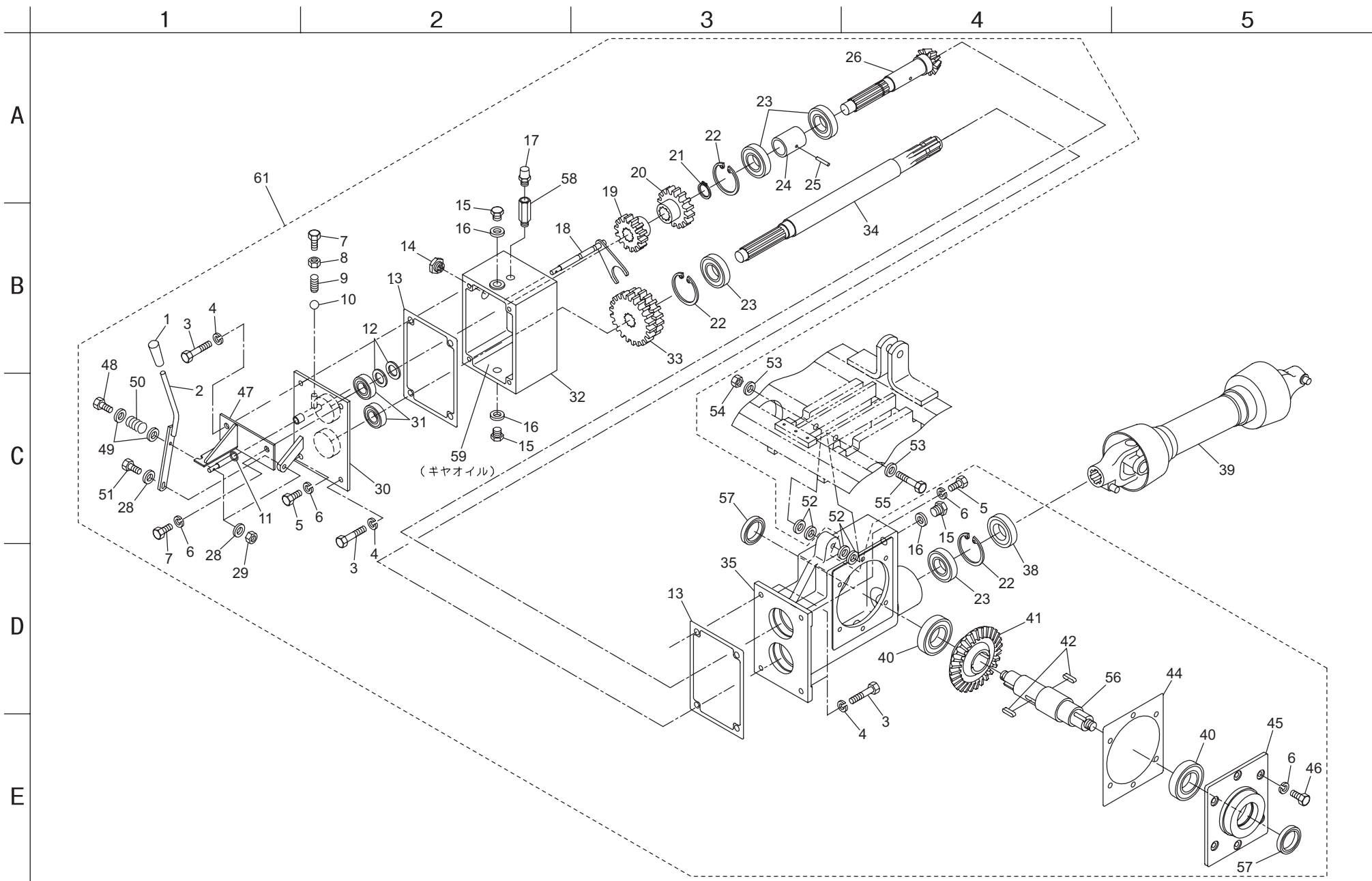

Cat No.	Code No.	Part name	Qty	Remarks
3 - 1	K1300000070	9 grip black 22	1	
3 - 2	TDA12000210Z2	Change lever	1	
3 - 3	K0071000652	10 knock bolt 50	4	
3 - 4	K0200120002	12S washer	4	
3 - 5	K0000100252	10 bolt 25	3	
3 - 6	K0200100002	10S washer	10	
3 - 7	K0000100302	10 bolt 30	2	
3 - 8	K0100100002	10 nut	1	
3 - 9	K1000000021	1.4 compression spring 7.816	1	
3 - 10	K1500800000	8 steel ball	1	
3 - 11	K0880011000	O-ring P11	1	
3 - 12	K5073225402	3.2SPHC washer 2540	2	
3 - 13	TDA12000215Z0	Packing A	2	
3 - 14	K1400000044-Y	PF 3/4 oil qty M type	1	
3 - 15	K1410000042-Y	14 plug P1.5	3	
3 - 16	K0920140000	14 seal washer S1	3	
3 - 17	K1430000012	Air breather PT 1/8	1	
3 - 18	TDA12000209A0	Shifter fork	1	
3 - 19	TDA12000208Z0	2-shaft 14-tooth gear	1	
3 - 20	TDA12000207Z0	2-shaft 16-tooth gear	1	
3 - 21	K0401030001	Stop ring S30	1	
3 - 22	K0402072001	Stop ring R72	3	
3 - 23	K0600062070	Bearing 6207	4	
3 - 24	K6215000270	35STMK collar with hole 45.158	1	
3 - 25	K0320060451	6 spring pin 45	1	
3 - 26	TDA12000205Z0	Derive shaft B	1	
3 - 27				
3 - 28	K5000060002	6 washer	3	
3 - 29	K0144060002	6U nut	2	
3 - 30	TDA12000203AR	Gearbox cover	1	
3 - 31	K0600062050	Bearing 6205	2	
3 - 32	TDA12000202ZR	Crank gearbox B	1	
3 - 33	TDA12000206Z0	1-shaft 20-tooth, 22-tooth gear	1	
3 - 34	TDA12000204Z0	Drive shaft A	1	
3 - 35	TDA12000201AR	Crank gearbox A	1	

Cat No.	Code No.	Part name	Qty	Remarks
3 - 36				
3 - 37				
3 - 38	K0862000050	Oil seal UE35729	1	
3 - 39	K1620000210	Drive shaft AS205-N400	1	
3 - 40	K0600062090	Bearing 6209	2	
3 - 41	TDA12000213Z0	30-tooth bevel gear	1	
3 - 42	K0500808310	8 both-end round key 831.5	2	
3 - 43				
3 - 44	TDA12000216Z0	Packing B	1	
3 - 45	TDA12000212AR	Crankshaft housing	1	
3 - 46	K0000100202	10 bolt 20	6	
3 - 47	TDA12000220ZR	Change guide	1	
3 - 48	K0000060502	6 bolt 50	1	
3 - 49	K5012306202	2.3SPCC washer 620	2	
3 - 50	K1000000309	1.6 compression spring 13.720	1	
3 - 51	K0000060252	6 bolt 25	1	
3 - 52	K6210000272	12.2 collar 256	4	
3 - 53	K5073212252	3.2SPCC washer 1225	2	
3 - 54	K0144120002	12U nut	1	
3 - 55	K0013121002	12 heat treated bolt 100	1	
3 - 56	TDA12000221Z0	Drive shaft C	1	
3 - 57	K0824062080	Oil seal MHSA40628	2	
3 - 58	TDA12000223Z2	Air breather pipe	1	
3 - 59	K2915000200	Gear oil VG680 20L can	-	Consumption = 3.8 L
3 - 60				
3 - 61	TDA12000222Z0	Gearbox Ass'y	1	

3. Gearbox

TDA1200

4. Crank

TDA1200

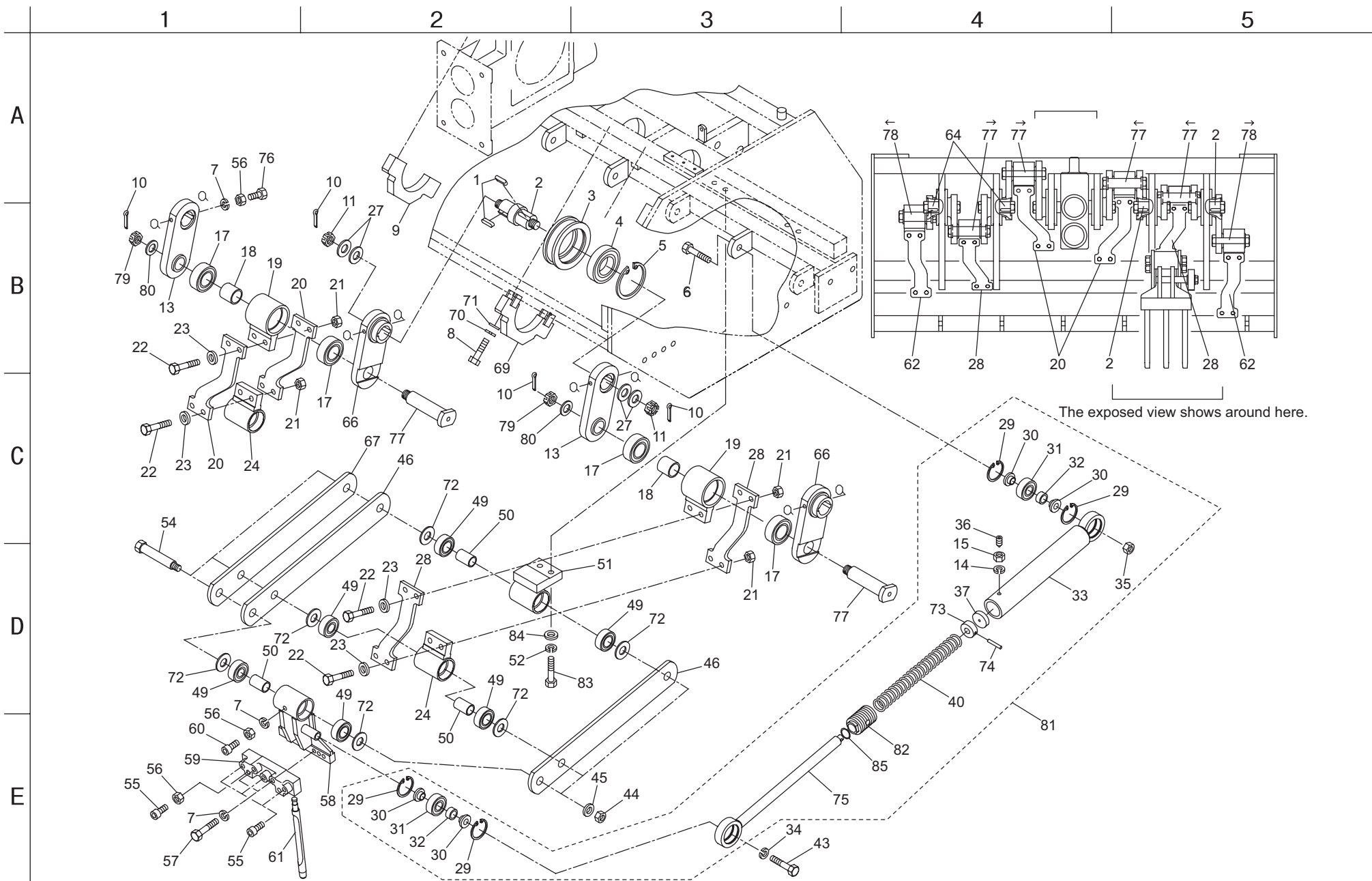

Cat No.	Code No.	Part name	Qty	Remarks
4 - 1	K0500808310	8 both-end round key 831.5	20	
4 - 2	TDA12000302Z0	Drive shaft right	2	
4 - 3	TDA12000304ZR	Crank housing	4	
4 - 4	K0608062090	Bearing 62092RS	4	
4 - 5	K0402085001	Stop ring R85	4	
4 - 6	K0013140502	14 heat treated bolt 50	6	
4 - 7	K0200100002	10S washer	38	
4 - 8	K0013120702	12 heat treated bolt 70	12	
4 - 9	TDA12000121AR	Housing mounting plate	2	
4 - 10	K0300032402	3.2 cotter pin 40	16	
4 - 11	TDA12000362Z8	20 nut A	10	
4 - 12				
4 - 13	TDA12000301AR	Crank bracket	4	
4 - 14	K0200080002	8S washer	6	
4 - 15	K0100080002	8 nut	6	
4 - 16				
4 - 17	K0608062060	Bearing 62062RD	12	
4 - 18	K6212002370	30STKM collar 3635	6	
4 - 19	TDA12000305AR	Upper housing	6	
4 - 20	TDA12000311AR	Upper arm A	4	
4 - 21	K0144120002	12U nut	24	
4 - 22	K0010120602	12 heat treated bolt 60	24	
4 - 23	K5000120002	12 washer	24	
4 - 24	TDA12000310AR	Lower housing A	6	
4 - 25				
4 - 26				
4 - 27	K0211200001	20 disc spring H	20	
4 - 28	TDA12000312AR	Upper arm B	4	
4 - 29	K0402047001	Stop ring R47	24	
4 - 30	TDA12000323Z2	Box lock collar	24	
4 - 31	K0613060050	Bearing 60052RDC3	12	
4 - 32	TDA12000324Z0	Urethane collar	12	
4 - 33	TDA12000318ZD	Spring box	6	
4 - 34	K0200140002	14S washer	6	
4 - 35	K0144140002	14U nut	6	

Cat No.	Code No.	Part name	Qty	Remarks
4 - 36	K0028080200	8 stainless hollow set 20	6	
4 - 37	TDA12000327Z0	Urethane seat	6	
4 - 38				
4 - 39				
4 - 40	K1000000870	4 compression spring 32260	6	
4 - 41				
4 - 42				
4 - 43	K0013140452	14 heat treated bolt 45	6	
4 - 44	K0145140002	14U nut P1.5	18	
4 - 45	K0212140002	14 disc spring washer 1L	18	
4 - 46	DA12000314ZR	Lower arm	12	
4 - 47				
4 - 48				
4 - 49	K0612062040	Bearing 62042RD	36	
4 - 50	K6212000180	20.2STKM collar 25.440	18	
4 - 51	TDA12000315ZR	Lower housing B	6	
4 - 52	K0200120002	12S washer	12	
4 - 53				
4 - 54	TDA12000335Z0	Arm shaft B1	18	
4 - 55	K0071001110	10 stainless steel hex socket head special bolt 30	30	
4 - 56	K0100100002	10 nut	38	
4 - 57	K0013100601	10 heat treated bolt 60	12	
4 - 58	TDA12000317BR	Tine holder	6	
4 - 59	TDA12000325A2	Φ12 Φ18 tine mounting plate	6	
4 - 60	K0024100251	10 hex socket head cap screw 25	6	
4 - 61	K2590000220	Φ17V tine 215	18	
4 - 62	TDA12000313AR	Upper arm C	4	
4 - 63				
4 - 64	TDA12000303Z0	Drive shaft left	2	
4 - 65				
4 - 66	TDA12000361AR	Crank metal fittings A	6	
4 - 67	TDA12000363ZR	Lock plate	6	
4 - 68				
4 - 69	TDA12000130AR	Housing mounting plate A	4	
4 - 70	K0200120002	12S washer	12	

4. Crank

TDA1200

4. Crank

TDA1200

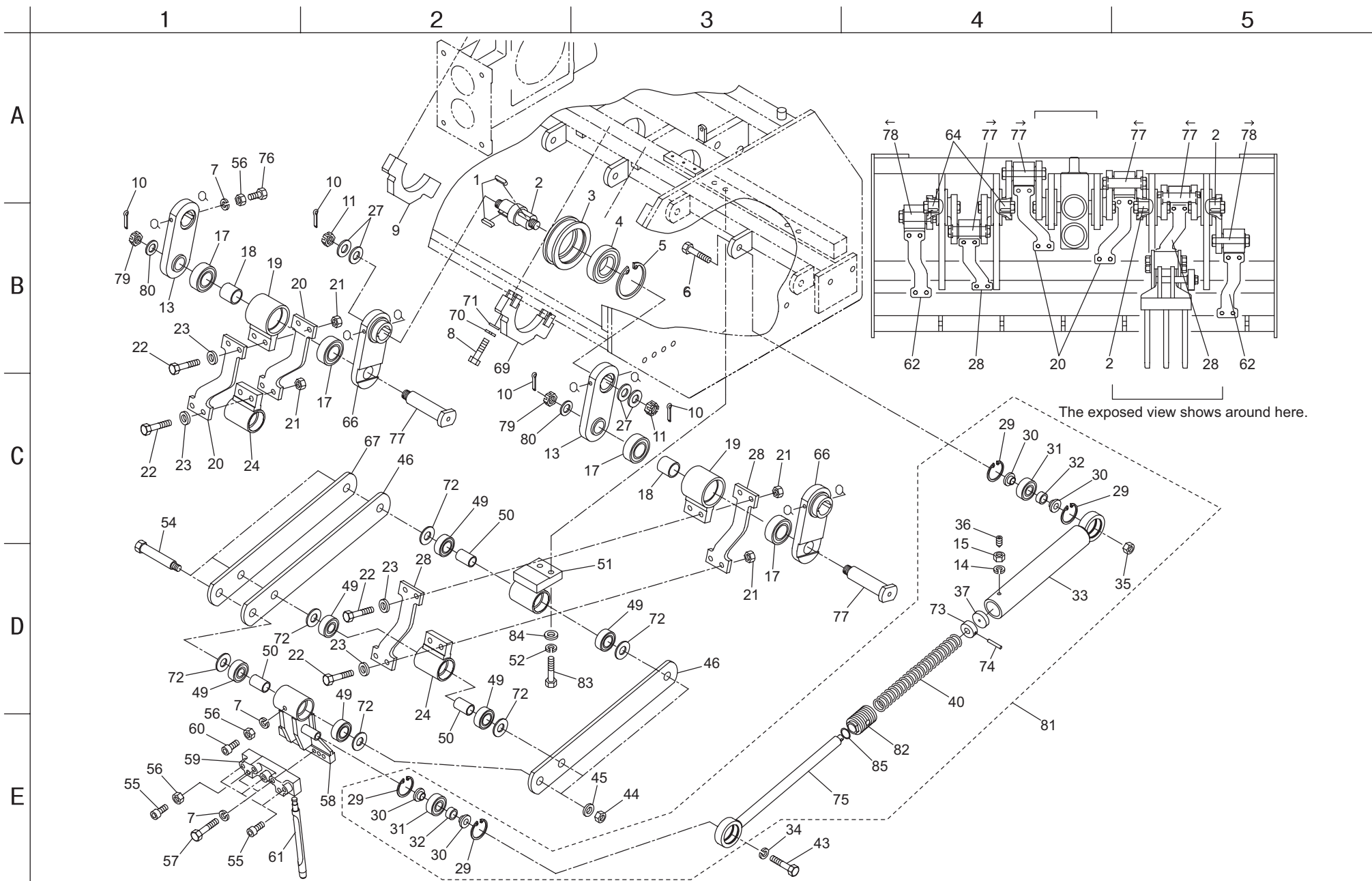

Cat No.	Code No.	Part name	Qty	Remarks
4 - 71	K5012312222	2.3SPCC washer 1222	12	
4 - 72	TDA12000336Z2	BG collar	36	
4 - 73	TDA12000365Z0	Spring clamping ring	6	
4 - 74	K0324080351	8 spiral pin 35	6	
4 - 75	TDA12000364ZD	Spring shaft	6	
4 - 76	K0010100402	10 heat treated bolt 40	20	
4 - 77	TDA12000371Z0	Crank shaft A24	4	
4 - 78	TDA12000372Z0	Crank shaft B24	2	
4 - 79	TDA12000370Z8	24 nut B	6	
4 - 80	K0212240001	24 disc spring washer 1L	6	
4 - 81	TDA12000373Z0	Spring box Ass'y	6	
4 - 82	TDA12000375Z0	Clamp A	6	
4 - 83	K0010120502	12 heat treated bolt 50	12	
4 - 84	K5074512252	4.5SPHC washer 1225	12	
4 - 85	K0880022000	O-ring P22	6	

Cat No.	Code No.	Part name	Qty	Remarks

4. Crank	TDA1200
-----------------	----------------

5. Accessories and options

TDA1200

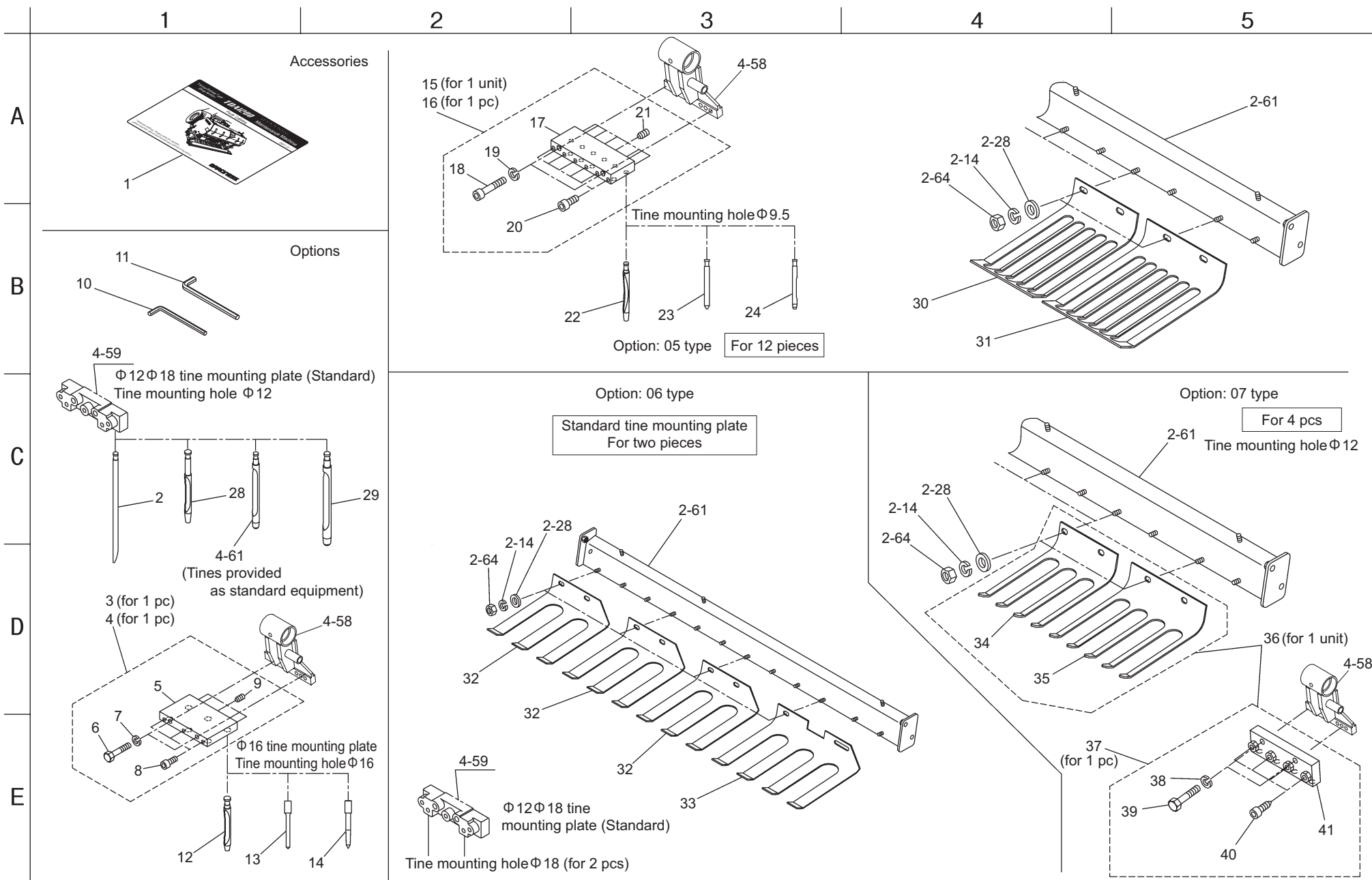

Cat No.	Code No.	Part name	Qty	Remarks
	Accessory			
5 - 1	750104-36	TDA1200 Parts Catalog	1	
	Option			
5 - 2	K2590000200	Φ12 solid tine 315	18	
5 - 3	TDA12000410Z0	Φ16 tine Ass'y	1	
5 - 4	TDA12000420Z0	Φ16 tine mounting plate Ass'y	6	
5 - 5	TDA12000401Z2	Φ16 tine mounting plate 6	6	
5 - 6	K0013101302	10 heat treated bolt 130	12	
5 - 7	K0200100002	10S washer	12	
5 - 8	K0060080150	8 stainless steel hex socket head bolt 15	18	
5 - 9	K0023080061	8 hollow set 6	18	
5 - 10	K4813040001	Allen wrench 4	1	
5 - 11	K4813060001	Allen wrench 6	1	
5 - 12	GA7000-1101Z0	Φ16V tine 125	36	
5 - 13	GA700--1130B0	Φ8 spike tine	36	
5 - 14	GA700--1135B0	Φ12.5 spike tine	36	
5 - 15	TDA12000510Z0	Φ12 tine Ass'y	1	
5 - 16	TDA12000520Z0	Φ12 tine mounting plate Ass'y	6	
5 - 17	GA1100-4402Z2	Φ12 tine mounting plate 12	6	
5 - 18	K0060100800	10 stainless steel hex socket head bolt 80	12	
5 - 19	K0200100002	10S washer	12	
5 - 20	K0060080150	8 stainless steel hex socket head bolt 15	36	
5 - 21	K0023080101	8 hollow set 10	36	
5 - 22	GA1100-9120Z0	Φ12V tine 120	72	
5 - 23	GA700--1150A0	Φ10 solid tine	72	
5 - 24	GA700--1145A0	Φ10V tine 100	72	
5 - 25				
5 - 26				
5 - 27				
5 - 28	K2590000240	Φ13V tine 225	18	
5 - 29	K2590000230	Φ17V tine 265	18	

Cat No.	Code No.	Part name	Qty	Remarks
5 - 30	TDA16000530ZD	Lawn push plate 8A for 12	5	
5 - 31	TDA16000531ZD	Lawn push plate 8B for 12	1	
5 - 32	TDA16000601ZD	Lawn push plate 8A for 2 pcs	3	
5 - 33	TDA16000602ZD	Lawn push plate 8B for 2 pcs	1	
5 - 34	TDA16000702ZD	Lawn push plate A for 4-12	5	
5 - 35	TDA16000703ZD	Lawn push plate B for 4-12	1	
5 - 36	TDA12000711Z0	4-12 holder part Ass'y	1	
5 - 37	TDA12000720Z0	4-12 holder Ass'y	6	
5 - 38	K0200100002	10S washer	12	
5 - 39	K0013100402	10 heat treated bolt 40	12	
5 - 40	K0071001110	10 stainless steel hex socket head special bolt 30	24	
5 - 41	TDA12000701Z2	4-12 holder	6	

5. Accessories and options

TDA1200

Postadress:

TRÄDGÅRDSTEKNIK AB
Helsingborgsvägen 578, Varalöv
262 96 ÄNGELHOLM

Telefon : 0431-222 90
Bg.nr : 5743-7980
Org.nr : 556409-6120

URL:

www.tradgardsteknik.se
E-postadress:
info@tradgardsteknik.se